

Code No: 121AC

JAWAHARLAL NEHRU TECHNOLOGICAL UNIVERSITY HYDERABAD

B.Tech I Year Examinations, May - 2016

ENGINEERING MECHANICS

(Common to CE, ME, MCT, MMT, AE, AME, MIE, PTE, CEE, MSNT)

Time: 3 hours

Max. Marks: 75

**Note:** This question paper contains two parts A and B.

Part A is compulsory which carries 25 marks. Answer all questions in Part A. Part B consists of 5 Units. Answer any one full question from each unit. Each question carries 10 marks and may have a, b, c as sub questions.

**PART- A****(25 Marks)**

- 1.a) State parallelogram law of forces. [2]
- b) What is free body diagram? Explain. [3]
- c) What is cone of friction? [2]
- d) What are different types of flat belt drives? [3]
- e) What is the importance of center of gravity? [2]
- f) Explain transfer formula for product of inertia. [3]
- g) A 5kg mass drops 2m upon a spring whose modulus is 10N/mm. What will be the speed of the block when the spring is deformed 100mm? [2]
- h) The position of a particle which moves along a straight line is defined by  $x=t^3-6t^2-15t+40$ .  $x$  is in meters,  $t$  is in seconds. Determine the distance travelled by the particle from  $t=4$ sec and  $t=6$ sec. [3]
- i) A 2HP motor of weight 18.5kg is mounted symmetrically on four identical springs each of stiffness 200gm/mm. Determine the frequency and the time period of vibration of the motor. [2]
- j) A force of 500N is acting on a block of mass 50kg resting on a horizontal surface. Determine its velocity after the block has travelled a distance of 10m. Coefficient of kinetic friction is 0.5. [3]

**PART-B****(50 Marks)**

2. The system shown in figure 1 consists of four cables EA, EB, EC and ED joined together at E. Cable ED passes over a small frictionless pulley at D and is used to apply the 5kN force needed to place the container G in position shown. If the tension in cable EA is 4.5kN, determine the mass  $m$  of the container G. [10]

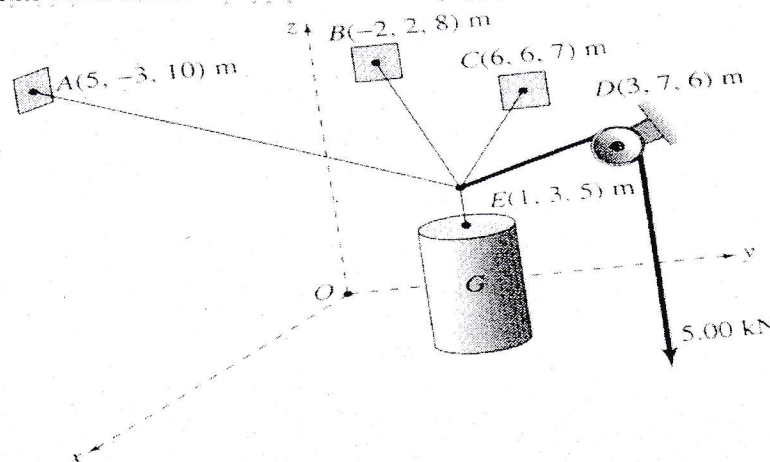
**Figure: 1**

OR

3. Figure 2 shows several identical smooth rollers of weight  $w$  each stacked on an inclined plane. Determine a) the maximum number of rollers which will lie in a single row as shown and b) all forces acting on roller A maximum number of rollers stacked in one row. [5+5]

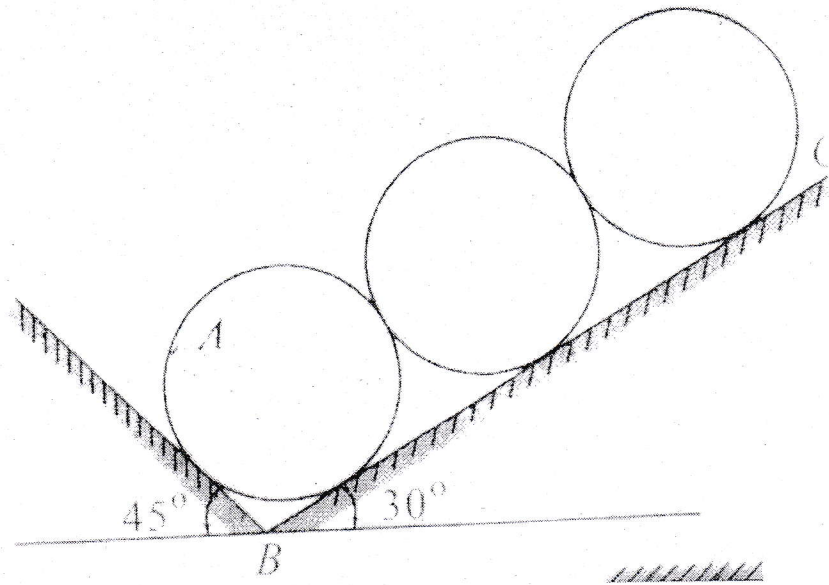

Figure: 2

4. A 18kg mass is hung from a lever which rests against a  $10^\circ$  wedge at A and is supported by a frictionless hinge at C. Knowing that the coefficient of static friction is 0.25 at both surfaces of the wedge and that for the position shown in figure 3 the spring is stretched 100mm, determine a) the magnitude of the force P for which motion of the wedge is impending, b) the components of the corresponding reaction at C. [5+5]

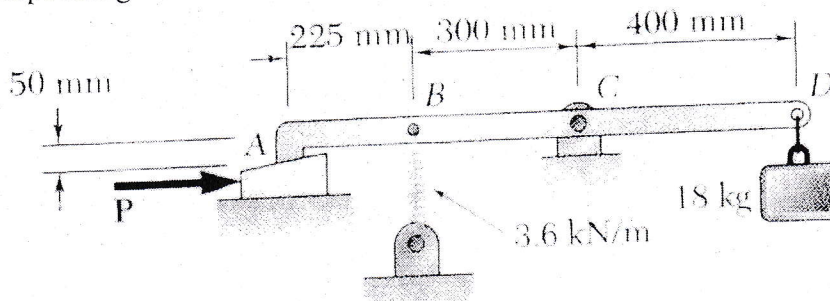

Figure: 3

OR

5. A belt 100mm wide and 8mm thick is transmitting power at a belt speed of 1600m/minute. The angle of lap of the smaller pulley is  $165^\circ$  and coefficient of friction is 0.3. The maximum permissible stress in the belt is  $2 \text{ N/mm}^2$  and the mass of the belt is  $0.9 \text{ kg/m}$ . Find the power transmitted and the initial tension in the belt. Also find the maximum power that can be transmitted and the corresponding belt speed. [10]

6. Determine the moment of inertia of the composite mass shown in figure 4 with respect to the Y-axis. What is the radius of gyration with respect this axis? The material has a mass density  $\rho=500\text{kg/m}^3$ . [10]

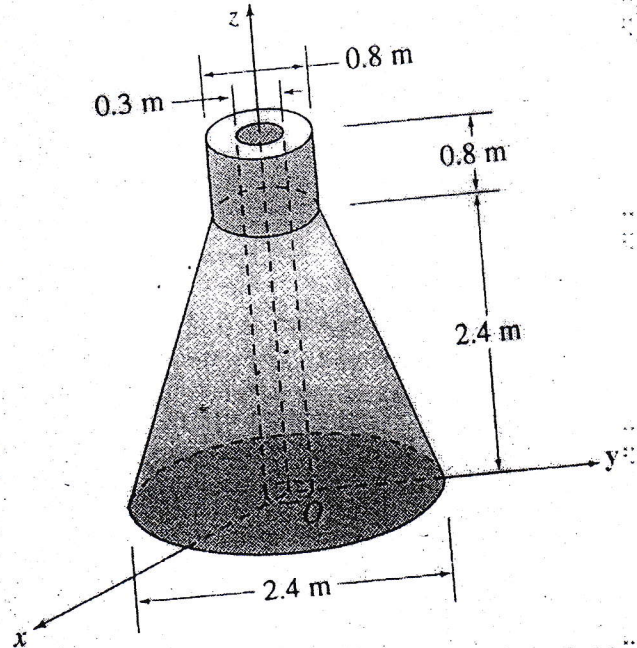

Figure: 4  
OR

- 7.a) State and prove theorem of Pappus.  
b) State and prove the equation for polar moment of inertia. [5+5]

8. A police officer in a petrol car parked in a 100km/hr zone observes a passing automobile travelling at a slow, constant speed. Believing that the driver of the automobile might be intoxicated, the officer starts his car, accelerates uniformly to 140km/hr in 8s, and maintaining a constant velocity of 140km/hr, overtakes the motorist 42s after the automobile passed him. Knowing that 18 s elapsed before the officer began pursuing the motorist, determine a) the distance the officer travelled before overtaking the motorist b) the motorist's speed. [5+5]

OR

9. A train weighing 400000kN is running up an inclined plane 1 in 100 at uniform speed of 54kmph. If the total resistance to motion is 0.5% of its weight, find the power exerted by the steam engine. If the steam is cut-off while the train is ascending the gradient, how far the train will go up the plane, before coming to rest, assuming the frictional resistance to remain constant during the travel. [10]

10. A bullet of mass 100gm is fired in to a freely suspended target of mass 10kg. Due to impact, the bullet gets embedded in the target and the target with bullet moves with a velocity of 7m/sec. Calculate the velocity of bullet and loss of kinetic energy. [10]

OR

11. A mass of 10kg is attached to a hanging spring of spring constant 750gm/mm. Derive the expressions for displacement and maximum velocity when a) the mass starts vibrating by displacing it 0.1m below its equilibrium position and b) the mass vibrates with initial velocity of 3.5m/s. [5+5]