

Code No: 126EE

R13

JAWAHARLAL NEHRU TECHNOLOGICAL UNIVERSITY HYDERABAD

B. Tech III Year II Semester Examinations, April - 2018

FINITE ELEMENT METHODS

(Common to AE, MSNT, ME)

Time: 3 hours

Max. Marks: 75

Note: This question paper contains two parts A and B. Part A is compulsory which carries 25 marks. Answer all questions in Part A. Part B consists of 5 Units. Answer any one full question from each unit. Each question carries 10 marks and may have a, b, c as sub questions.

PART - A

(25 Marks)

- 1.a) What boundary conditions are imposed for 1 Dimensional bar element. [2]
- b) Discuss the shape functions of one dimensional quadratic element. [3]
- c) Write the hermitian shape function of a beam element. [2]
- d) How local and global coordinates are related in a truss problem. [3]
- e) What are the properties of a triangular coordinates. [2]
- f) Write the strain displacement equation of axisymmetric problems using a cylindrical coordinate system. [3]
- g) List one requirement which is sufficient for convergence for a plate element. [2]
- h) Write governing differential equation for two dimensional heat transfer problem [3]
- i) Describe the features of NISA software. [2]
- j) Differentiate lumped and consistent mass matrix. [3]

PART - B

(50 Marks)

2. Derive the stiffness matrix and consistent load vector in matrix form for one dimensional quadratic element. [10]
- OR
3. Explore the stress strain relation for 2D and 3D elastic problems. [10]
4. Determine the nodal displacement of the following truss as shown in figure 1. [10]

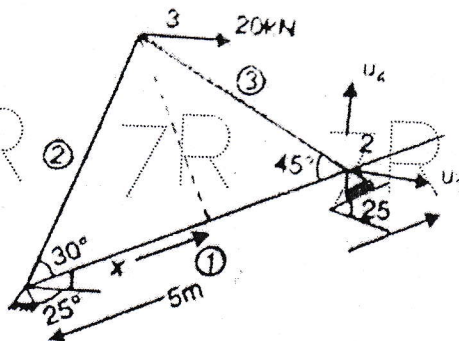

Figure 1

5. Determine the slope and vertical deflection at the centre for the following beam figure 2. [10]

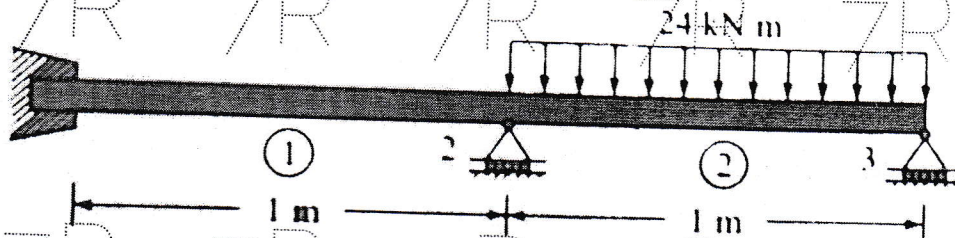

Figure 2

6. Derive the area and strain displacement matrix for the triangular element and thus calculate the same for the triangle as shown in figure 3. [10]

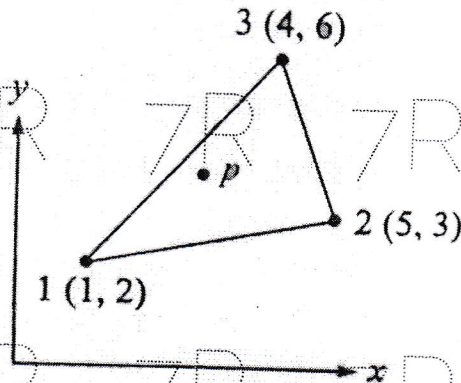

Figure 3

7. Derive the element stiffness matrix for the following figure 4 axisymmetric annular ring element. [10]

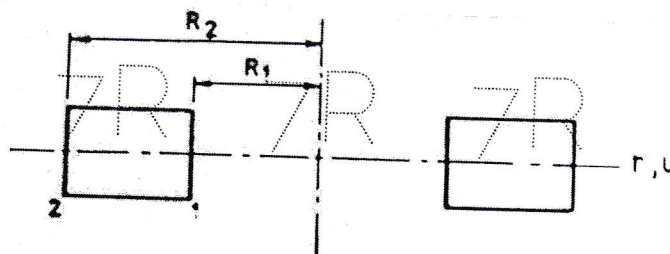

Figure 4

8. Use galerkin's approach to find the stiffness matrix of a torsional triangular element. [10]

9. Determine the temperature distribution in a fin having rectangular cross section and is 8 cm long, 4 cm wide and 1 cm thick. Assume convection heat loss occurs from the free end of the fin. One end is fixed. Take  $k=3 \text{ W/cm}^0\text{C}$ ,  $h= 0.1 \text{ W/cm}^2 \text{ }^0\text{C}$  and  $T_{\infty}=20^0\text{C}$ . [10]

7R 7R 7R 7R 7R 7R 7R

10. Find the natural frequency of the following truss bar figure 5.

[10]

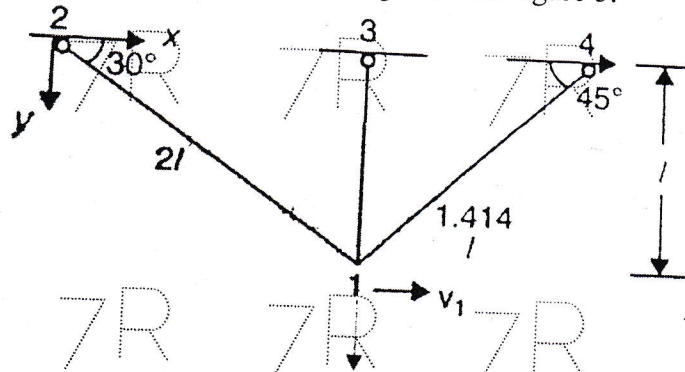

Figure 5  
OR

11. Derive the eigen values and eigen vectors of the stepped bar. Assume the required data.

[10]

7R 7R 7R 7R 7R 7R 7R  
---ooOoo---

7R 7R 7R 7R 7R 7R 7R

7R 7R 7R 7R 7R 7R 7R

7R 7R 7R 7R 7R 7R 7R

7R 7R 7R 7R 7R 7R 7R